

Loss-In-Weight Feeder

Models VTF200 to VTF600

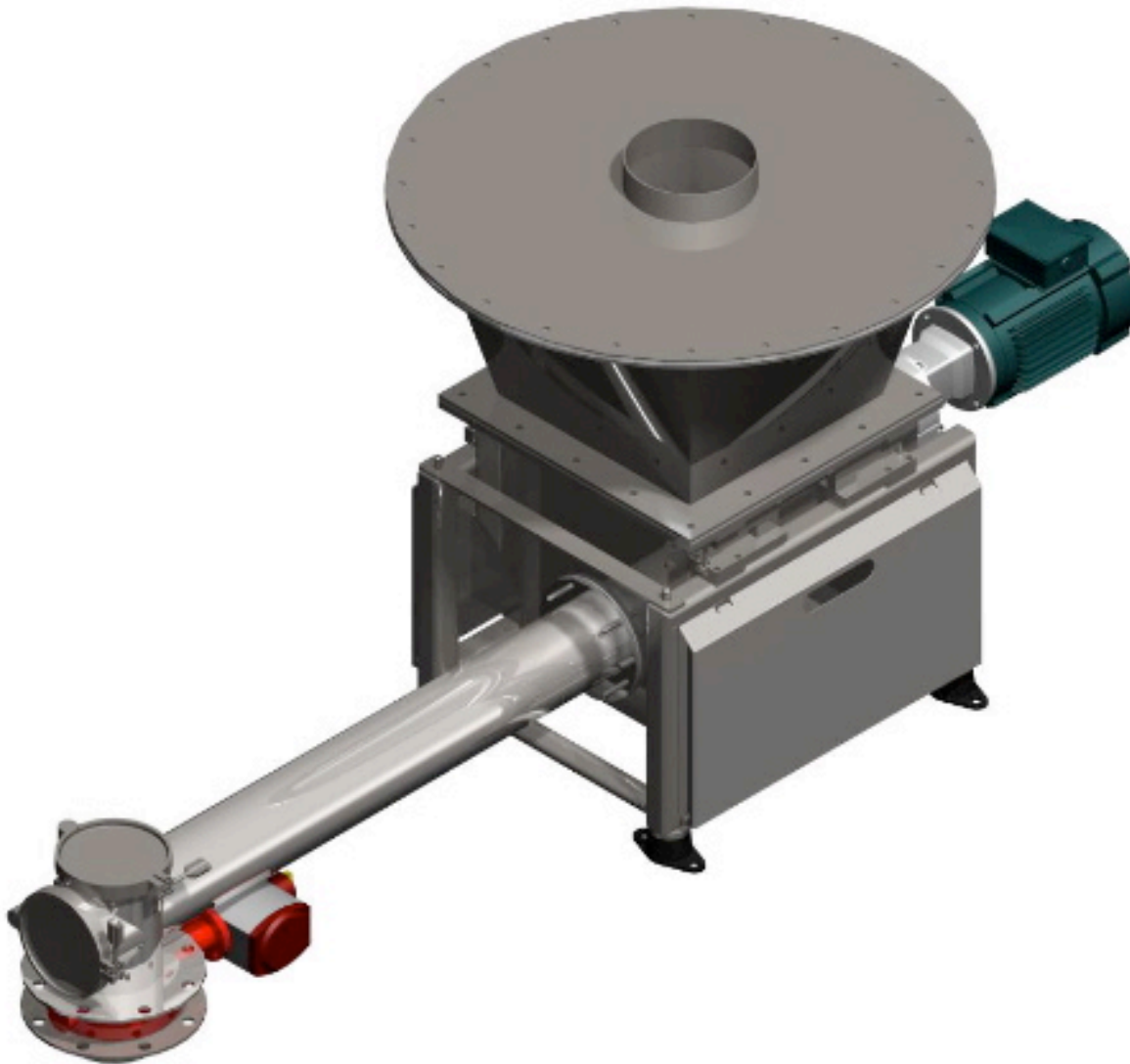

Tool Free Take Apart Process Equipment and Systems



RELEVANT TRANSFORMATION

Modular design consists drive, auger, variable length tube, boot, mounting frame and scale set. Any tube and auger can be mated to boot section. Optional agitator can be added at any time. This feeder transforms to meet your needs.

STREAMLINED DESIGN

Direct drive eliminates messy chains and gears. Drive is offered with C-face adapter that utilizes standard C-face motor. Air purge seals are standard on all feeders. Assembly is vacuum tight and is suitable for using in a vacuum system without the need for isolation valve.

SOLID CONTROL

Feed auger is available in a range of pitches that produce a flight that runs at optimal speed. Precise metering results from close tolerance auger to tube fitment. Optional double flights are available for maximum powder control.

QUICK TAKE APART

Both ends of feeder are easily dis-assembled. Auger can be tool free removed from housing for easy cleaning. Drive assembly swings free for easy seal access.

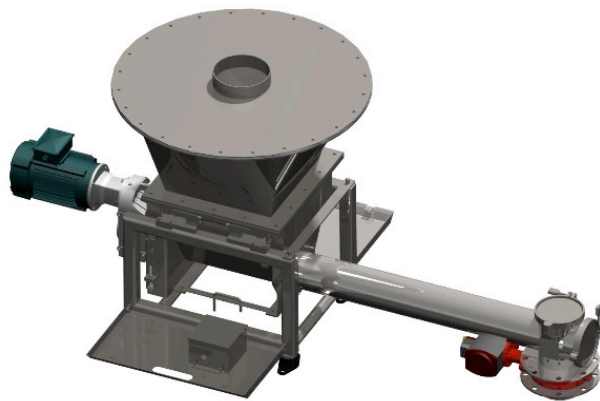

Loss In Weight Feeder

Available in a range from 2" diameter to 6" diameter augers. Feed capacity to over 250 PPM is possible. All tool free quick take apart provides quick cleaning.

ROBUST CONSTRUCTION

Feeder rides in a square tube frame that mates scales to feeder. Heavy end plates provide a simple and robust platform.



2005 Gateway Circle
Centerville, MN 55038
PH: 651-653-5098
FX: 651-653-4035
www.hafequipment.com